

Financial (in)stability,
supervision and liquidity injections:
a dynamic general equilibrium approach



Working Paper Research

by Gregory de Walque, Olivier Pierrard and Abdelaziz Rouabah

October 2008 **No 148**

Editorial Director

Jan Smets, Member of the Board of Directors of the National Bank of Belgium

Editorial

On October 16-17, 2008 the National Bank of Belgium hosted a Conference on "*Towards an integrated macro-finance framework for monetary policy analysis*".

Papers presented at this conference are made available to a broader audience in the NBB Working Paper Series (www.nbb.be).

Statement of purpose:

The purpose of these working papers is to promote the circulation of research results (Research Series) and analytical studies (Documents Series) made within the National Bank of Belgium or presented by external economists in seminars, conferences and conventions organised by the Bank. The aim is therefore to provide a platform for discussion. The opinions expressed are strictly those of the authors and do not necessarily reflect the views of the National Bank of Belgium.

Orders

For orders and information on subscriptions and reductions: National Bank of Belgium,
Documentation - Publications service, boulevard de Berlaimont 14, 1000 Brussels

Tel +32 2 221 20 33 - Fax +32 2 21 30 42

The Working Papers are available on the website of the Bank: <http://www.nbb.be>

© National Bank of Belgium, Brussels

All rights reserved.

Reproduction for educational and non-commercial purposes is permitted provided that the source is acknowledged.

ISSN: 1375-680X (print)

ISSN: 1784-2476 (online)

Financial (in)stability, supervision and liquidity injections: a dynamic general equilibrium approach*

Gregory de Walque[†]
Olivier Pierrard[‡]
Abdelaziz Rouabah[§]

October 2008

Abstract

This paper develops a dynamic stochastic general equilibrium model with interactions between an heterogeneous banking sector and other private agents. We introduce endogenous default probabilities for both firms and banks, and allow for bank regulation and liquidity injection into the interbank market. Our aim is to understand the importance of supervisory and monetary authorities to restore financial stability. The model is calibrated against real data and used for simulations. We show that liquidity injections reduce financial instability but have ambiguous effects on output fluctuations. The model also confirms the partial equilibrium literature results on the procyclicality of Basel II.

Keywords: DSGE, Banking sector, Default risk, Supervision, Money

JEL classification: E13, E20, G21, G28

*The views expressed in this paper are personal views of the authors and do not necessarily reflect those of the National Bank of Belgium, the Central Bank of Luxembourg or the Eurosystem.

[†]National Bank of Belgium and University of Namur, Email: gregory.dewalque@nbb.be.

[‡]Central Bank of Luxembourg and Catholic University of Louvain, Email: olivier.pierrard@bcl.lu.

[§]Central Bank of Luxembourg, Email: abdelaziz.rouabah@bcl.lu.

1 Introduction

In neoclassical models, the capital market is perfectly competitive and investment is simply determined by the marginal cost of capital. More fundamentally, in these models, the capital market is not distorted by taxes, transaction or bankruptcy costs, imperfect information or any other friction which limits access to credit, so the Modigliani and Miller (1958) theorem holds meaning that financial and credit market conditions become irrelevant and cannot affect real economic outcomes. However, credit market imperfections are often considered a crucial contributing factor to the severity of crises, for instance during the Great Depression or more recently the subprime crises and associated financial turmoil. This central role of the credit market may in turn explain why banking remains so heavily regulated despite the significant deregulation in recent decades in many other industries. This may also explain why central banks react so rapidly to financial crises, despite the risk of creating moral hazard.

The main objective of this paper is to build a dynamic stochastic general equilibrium model with imperfections in the credit market, such that the Modigliani and Miller (1958) theorem no longer holds. More precisely, following Goodhart et al. (2006), we develop an heterogeneous banking sector and allow for bank regulation, liquidity injections and endogenous default probabilities for both firms and banks, with default costs. We embed this banking sector representation in an otherwise standard real business cycle model (hereafter RBC, see King and Rebelo (1999) for an extensive exposition). We start from the RBC model because it is now widely accepted as a benchmark in the literature. Moreover, in the limiting case of no default rates and no supervisory and monetary authorities, our model generates results similar to those of the RBC model. We then develop a plausible calibration and use our model to understand the role of supervisory and monetary authorities in restoring financial stability.

Carlstrom and Fuerst (1997) introduce credit market frictions through asymmetry of information between lenders and borrowers as well as agency costs. Kiyotaki and Moore (1997), Bernanke et al. (1999) (BGG hereafter) or Cooley et al. (2004) adopt this approach in a dynamic general equilibrium model and assess the quantitative implications of credit frictions for the real economy. BGG show that their model generates a procyclical pattern in the net worth of firms/borrowers, which in turn implies a countercyclical risk premium that acts as a financial accelerator. These models only focus on the demand side of the credit market and banks are limited to act as intermediaries between households (lenders) and firms (borrowers). Meh and Moran (2004) argue that banks themselves are also subject to frictions in raising loanable funds. They extend the BGG model and show that the supply side of the credit market (bank balance sheet) also contributes to shock propagation. However, their capital-asset ratio is market-determined rather than originating from regulatory requirements. Markovic (2006) develops a closely related model in which banks must raise capital reserves (or reduce their

loan supply) to fulfill regulatory requirements. Results suggest that the bank capital channel contributes significantly to the monetary transmission mechanism, along with the corporate balance sheet channel. Goodfriend and McCallum (2007) formulate a quantitative model to assess the relevance of a detailed banking sector (and hence the importance of distinguishing among the various short term interest rates) for monetary policy. Miyake and Nakamura (2007) provide a different approach by using an overlapping generations model with strategic complementarities between bank equity and the capital of other firms in the economy. In the short run, bank capital regulation amplifies the effects of a productivity shock. In the long run, tougher capital requirements boost bank capital.¹

All the papers mentioned above use an homogeneous agent to represent the banking sector, which can be either a set of identical and perfectly competitive banks or a single monopolist. But Goodhart et al. (2006) warn that ignoring the existence of the interbank market obscures all the relationships between banks which interest supervisory authorities and central banks. Goodhart et al. (2005) develop a model including a commercial banking sector with an explicit interbank market and bank endogenous default rates. Since the main focus of their paper is financial fragility, a financial regulator imposes a range of penalties in case of default or non respect of capital adequacy ratio. A central bank is also included on the interbank market. However, if the “core” banking sector is extensively developed and micro-founded, the “periphery” agents are modeled through reduced form equations. In addition, this is only a 2-period model which cannot track dynamic effects of shocks or policies.² They calibrate the model using UK banking data and do not find serious contagion in the interbank market. They show that contagion is diminished if the central bank targets interest rates.

Our model includes one agent that borrows (representative firm) and one that lends (representative household), as well as a competitive banking market which is composed of two banks (a net lender and a net borrower on the interbank market). As in Goodhart et al. (2005), we assume that agents (firms and banks) may default on their financial obligations, subject to default costs. Our model is fully microfounded in the sense that all agents maximise profits or utility under constraints. Moreover, we have capital regulation rules set by a supervisory authority and we allow for monetary policy through liquidity injections into the interbank market. We therefore have a banking sector representation close to Goodhart et al. (2005), but we embed it in a fully micro-founded dynamic (intertemporal) stochastic general equilibrium model. As underlined in Borio and Zhu (2007), this is the only framework in which dynamic interactions

¹This literature review is far from being exhaustive and we concentrate on dynamic general equilibrium models. For an extended survey, see for instance VanHoose (2008).

²Decisions under uncertainty (2 possible future scenarios) are taken in period 1. In period 2 the state of the world is revealed and contracts are settled.

between agents and policy effects can be properly assessed.

We use average historical values on interest rates, default rates as well as banking and macroeconomic aggregated data to calibrate the model.³ We introduce a productivity shock (TFP shock) and we simulate the model under different policy regimes: no liquidity injections *vs.* discretionary liquidity injections, and Basel I regulations *vs.* Basel II regulations (risk-sensitive own fund requirements). We first show that endogenous default rates generate countercyclical risk premia acting as financial accelerators, and that our model is able to reproduce stylized facts on interest rates and default rates. Second, we confirm the partial equilibrium literature results on the procyclicality of a Basel II regime. Finally, looking at optimal monetary policy, we show that liquidity injections reduce financial instability but have ambiguous effects on output volatility.

Section 2 introduces the model. Section 3 describes the banking sector in Luxembourg and explains the calibration. Section 4 provides simulations and presents the main results. Section 5 concludes.

2 Model

We depart from the standard RBC model with a perfectly competitive capital (or credit) market between households/lenders and firms/borrowers by introducing a banking sector. More precisely, we assume that households deposit savings with a bank and that firms borrow capital from a bank. In this setup, bank deposits (from households) may differ from bank loans (to firms) and the interest rate on deposits (lending rate) may differ from the interest rate on loans (borrowing rate) generating an interest rate spread.⁴

A second departure from the standard model is the introduction of an interbank market: banks receiving deposits from households (excess liquidity) are different from banks supplying loans to firms (liquidity shortage) and equilibrium is restored through the interbank market.⁵ The interbank interest rate is free to move (no central bank intervention) or alternatively, the central

³The model is calibrated against Luxembourg data because of the importance of the banking sector in this country and the availability of data.

⁴Since bank loans are risky whereas bank deposits are not (see below), the interest rate spread is called risk premium.

⁵Again, interbank loans are risky (see below) and the interest rate spread with the deposit rate includes a risk premium. In the subsequent analysis, we call “borrowing banks” those who borrow on the interbank market and lend to firms, and “lending banks” those who lend on the interbank market and collect deposits from households. Alternatively, we could argue we have two types of specialized banks: deposit banks collecting deposits and merchant banks lending to firms.

bank may inject or remove liquidity to influence the interbank rate.

We also introduce endogenous probabilities of default for firms and borrowing banks. In other words, a firm problem may increase its default rate, producing bank repayment problems on the interbank market. It is worth noting that we do not have a default possibility for the lending banks. We believe this is a fair representation of reality because a deposit guarantee scheme exists in all OECD countries.⁶ Finally, we have a supervisory authority, fixing own fund requirements for banks. These requirements may be independent from the business cycle (Basel I) or risk-sensitive (Basel II).

We therefore have six agents in our model: firms, borrowing banks, lending banks, households, a supervisory authority and a central bank. The relationships between these six agents are summarized in Figure 1. Without defaults and hence without supervision, the distinction between the three interest rates would become irrelevant and our model would simplify into a standard RBC one.

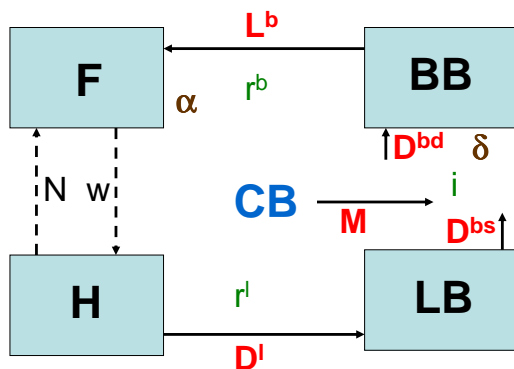

Figure 1: Flows between agents

2.1 Firms

We assume risk-neutral firms maximising profits π_t^f .⁷ The firms may default with a probability $1 - \alpha_t$. As Dubey et al. (2005) or Elul (2008), we do not exclude defaulters but we discourage default through costs, *i.e.* firms choose whether to repay or to bear costs for defaulting. Costs are both non pecuniary (disutility or “social stigma”: reputation losses, pangs of conscience) and pecuniary (higher search costs to obtain new loans because of the bad reputation). The

⁶As a result, no major OECD bank defaulted on its obligations to depositors over the last decades.

⁷Risk-neutrality for firms is a usual assumption in the RBC literature.

firm maximization program is:⁸

$$\max_{N_t, L_t^b, \alpha_t} \sum_{s=0}^{\infty} \tilde{\beta}_{t+s} \left\{ \pi_{t+s}^f - d_f (1 - \alpha_{t+s}) \right\}, \quad (1)$$

under the constraints:

$$K_t = (1 - \tau)K_{t-1} + \frac{L_t^b}{1 + r_t^b}, \quad (2)$$

$$\pi_t^f = \epsilon_t \mathcal{F}(K_t, N_t) - w_t N_t - \alpha_t L_{t-1}^b - \frac{\gamma}{2} \left((1 - \alpha_{t-1}) L_{t-2}^b \right)^2 - \frac{\theta}{2} \left(\frac{L_t^b}{1 + r_t^b} - \frac{L_{t-1}^b}{1 + r_{t-1}^b} \right)^2 \quad (3)$$

$$\tilde{\beta}_{t+s} = \beta^s \frac{\mathcal{U}_{C_{t+s}}}{\mathcal{U}_{C_t}}. \quad (4)$$

Equation (2) is the law of motion for capital. Capital K_t depreciates at a rate τ and firms borrow L_t^b at a price $1/(1 + r_t^b)$ to refill their capital stock.⁹ Equation (3) defines profit. The firms produce goods using capital and labour N_t as input, and ϵ_t is a total factor productivity shock. They pay a wage w_t to workers and reimburse their previous period borrowings L_{t-1}^b . They choose what proportion α_t of their previous borrowing they want to repay, knowing that they will have to pay tomorrow a quadratic search cost on any defaulted amount (and also bear a disutility). Finally, we assume a quadratic borrowing adjustment cost similar to the investment cost of the DSGE literature (see for instance Smets and Wouters (2003) or Christiano et al. (2005)). Firms are ultimately owned by households and their discount factor is therefore given by equation (4), where \mathcal{U}_{C_t} represents the marginal utility of consumption and β the discount factor.

The first order conditions are developed in Appendix A.

2.2 Banks borrowing from the interbank market (merchant banks)

Merchant banks borrow D_t^{bd} from the interbank market and lend L_t^b to firms. They also invest B_t^b in their market book and keep F_t^b as own funds. Their balance sheet is therefore:

Assets	Liabilities
Loans to firms (L^b)	Own funds (F^b)
Market book (B^b)	Interbank deposits (D^{bd})

⁸A more careful notation should include the conditional expectation operator, *i.e.* Z_{t+j} stands for $E_t [Z_{t+j}]$, where Z may be any variable or combination of variables. Our simplified notation is however easier to read.

⁹The interest rate is predetermined meaning it is fixed (contract between firms and banks) at the borrowing time t and not at the repayment time $t + 1$. We think this is a plausible representation of reality. Moreover, without predetermination, the endogenous default choice would be irrelevant because it would be totally offset by an interest rate increase.

We assume risk-averse banks maximising the net present value of the flows of expected profits π_t^b and having disutility from its default rate $1 - \delta_t$.¹⁰ We follow Goodhart et al. (2005) by assuming a positive utility for the buffer of own funds F_t^b above the minimum capital requirement imposed by the financial supervisory authority which fixes the coverage ratio of risky assets k , together with $\bar{\omega}_t$ and $\tilde{\omega}$ the respective weights on loans and on the market book (and $\bar{\omega}_t$ may vary over time, see subsection 2.6 below).¹¹ The bank maximization program is:

$$\max_{\delta_t, D_t^{bd}, L_t^b} \sum_{s=0}^{\infty} \tilde{\beta}_{t+s} \left\{ \ln \left(\pi_{t+s}^b \right) - d_{\delta} (1 - \delta_{t+s}) + d_{F^b} \left(F_t^b - k \left[\bar{\omega}_t L_t^b + \tilde{\omega} B_t^b \right] \right) \right\}, \quad (5)$$

under the constraints:

$$F_t^b = (1 - \zeta_b) F_{t-1}^b + v_b \pi_t^b, \quad (6)$$

$$\begin{aligned} \pi_t^b = & \alpha_t L_{t-1}^b + \frac{D_t^{bd}}{1 + i_t} - \delta_t D_{t-1}^{bd} - \frac{L_t^b}{1 + r_t^b} - \frac{\omega^b}{2} \left((1 - \delta_{t-1}) D_{t-2}^{bd} \right)^2 \\ & + \zeta_b (1 - \alpha_{t-1}) L_{t-2}^b + \phi_t^b, \end{aligned} \quad (7)$$

with ζ_b, ζ_b and $v_b \in [0, 1]$. Equation (6) states that own funds are increased each period by the share v_b of profits that are not redistributed to the households-shareholders. Furthermore, a small fixed proportion ζ_b of the own funds are put in an insurance fund managed by a public authority. Equation (7) defines the period profit. The bank borrows D_t^{bd} on the interbank market at a price $1/(1 + i_t)$. It chooses the fraction δ_t of past borrowing it wants to pay back, knowing that it will have to pay tomorrow a quadratic search cost on her defaulted amount.¹² Because of the existence of the insurance fund, the bank is able to recover a fraction of the firms' defaulted amount. The last variable on the right-hand side collects the market book terms. The market book net return is $(1 + \rho_t) B_{t-1}^b - B_t^b$. In this paper we assume an exogenous market book volume $B_t^b = \bar{B}^b$ and an exogenous return $\bar{\rho}$, hence $\phi_t^b = \bar{\rho} \bar{B}^b$.

The first order conditions are developed in Appendix A.

2.3 Banks lending to the interbank market (deposit banks)

Deposit banks lend D_t^{bs} to the interbank market and receive deposits D_t^l from households. They also invest B_t^l in the market book and keep F_t^l as own funds. Their balance sheet is therefore:

¹⁰See for instance Goodhart et al. (2005) for a similar risk-aversion assumption. As was the case for firms, default disutility may represent "social stigma".

¹¹In practice, the regulator sets a minimum capital requirement and penalties are paid in case of violation. Since we want to rule out a corner solution in our model, we simply assume that banks want to keep a buffer above the required minimum in order to avoid penalties. This buffer assumption does not seem unrealistic and is found in data (see section 3.2). As underlined in Borio and Zhu (2007), crossing the capital threshold is extremely costly for a bank (restrictive supervisory actions, market reaction, reputation losses) and would be regarded as the "kiss of death".

¹²See previous subsection for a justification. This can be also interpreted as a penalty cost paid to the supervisory authority.

Assets	Liabilities
Interbank loans (D^{bs})	Own funds (F^l)
Market book (B^l)	Deposits from households (D^l)

We assume risk-averse banks maximising profits π_t^l . As the merchant banks, they derive utility from the buffer of own funds above the capital requirement imposed by the supervisory authority. The latter fixes the coverage ratio of risky assets k , as well as $\bar{\omega}$ and $\tilde{\omega}$, the weights associated respectively on interbank loans and on the market book. Their maximization program is

$$\max_{D_t^{bs}, D_t^l} \sum_{s=0}^{\infty} \tilde{\beta}_{t+s} \left\{ \ln \left(\pi_{t+s}^l \right) + d_{Fl} \left(F_t^l - k \left[\bar{\omega} D_t^{bs} + \tilde{\omega} B_t^l \right] \right) \right\}, \quad (8)$$

under the constraints:

$$F_t^l = (1 - \xi_l) F_{t-1}^l + v_l \pi_t^l, \quad (9)$$

$$\pi_t^l = \delta_t D_{t-1}^{bs} + \frac{D_t^l}{1 + r_t^l} - D_{t-1}^l - \frac{D_t^{bs}}{1 + i_t} + \zeta_l (1 - \delta_{t-1}) D_{t-2}^{bs} + \phi_t^l, \quad (10)$$

with ζ_l, ξ_l and $v_l \in [0, 1]$. Equation (9) displays the own funds dynamic: own funds F_t^l are increased each period by the share v_l of profits that are not redistributed to the households-shareholders. Furthermore, a small fixed proportion ξ_l of the own funds are put in an insurance fund managed by a public authority. Equation (10) defines the bank's profit. It pays a net return $r_t^l / (1 + r_t^l)$ on deposits from households and receives a gross return $i_t / (1 + i_t)$ from loans on the interbank market, the net return varying along with the merchant banks default rate $(1 - \delta_t)$. Note that a fraction of the defaulted amount (by the defaulting merchant banks) is paid back to the deposit banks from the insurance fund managed by the public authority. We assume that the lending banks never default, that is they always repay 100% of deposits. The last variable on the right-hand side collects the market book terms. The market book net return is $(1 + \rho_t) B_{t-1}^l - B_t^l$. In this paper we assume exogenous market book volume $B_t^l = \bar{B}^l$ and an exogenous return $\bar{\rho}$, hence $\phi_t^l = \bar{\rho} \bar{B}^l$.

The first order conditions are developed in Appendix A.

2.4 Households

As in the standard RBC literature, we assume risk-averse households maximising the utility of consumption C_t and leisure $1 - N_t$. We also impose a target in deposits (households do not like deposits differing from their long run optimal level) through a quadratic disutility term.¹³ The

¹³ We also introduce the convex disutility term for technical reasons. If $\chi = 0$, both equations (A9) and (A12) give the steady state for r_t^l , leaving D_t^l undetermined (singular matrix). By imposing $\chi > 0$, we force equation (A12) to determine the steady state of D_t^l . Note that in our calibration, χ is kept close to zero. Alternatively, we could

household maximization program is:

$$\max_{N_t, C_t} \sum_{s=0}^{\infty} \beta^s \left\{ \mathcal{U}(C_{t+s}) + \bar{m} \ln(1 - N_{t+s}) - \frac{\chi}{2} \left(\frac{D_{t+s}^l}{1 + r_{t+s}^l} - \frac{\bar{D}^l}{1 + r^l} \right)^2 \right\}, \quad (11)$$

under the budget constraint:

$$C_t + \frac{D_t^l}{1 + r_t^l} = w_t N_t + D_{t-1}^l + \pi_t^f + (1 - v_b) \pi_t^b + (1 - v_l) \pi_t^l. \quad (12)$$

The first order conditions are developed in Appendix A.

2.5 Central bank

In the long run, we assume equilibrium in the interbank market, that is $D^{bd} = D^{bs}$. However, in the short run, the central bank may inject ($M_t > 0$) or withdraw liquidities ($M_t < 0$) such that:

$$M_t = D_t^{bd} - D_t^{bs}. \quad (13)$$

The liquidity operation M_t follows a simplified McCallum (1994) rule:

$$M_t = \nu (i_t - \bar{i}), \quad (14)$$

with $\nu \geq 0$, such that M_t increases (resp. decreases) when the interbank rate is higher (resp. lower) than the desired value \bar{i} .¹⁴ If $\nu = 0$, there is no central bank intervention and the interbank interest rate clears the interbank market.¹⁵

2.6 Supervisory authority

The supervisory authority fixes the capital requirement ratio k and the weights $\bar{\omega}_t$, $\bar{\omega}$ and $\bar{\omega}$ associated with the different kinds of risky assets. We assume that under Basel I regulations, all weights are constant and in particular $\bar{\omega}_t = \bar{\omega}$. Basel II regulations offer more sophisticated and informative measures of risks and capital adequacy. In particular, in our model, we assume that the credit weight associated to loans to firms is risk-sensitive. If the expectations of firm default increase, the associated weight also increases:

introduce a bank production function and assume that $D_t^l / (1 + r_t^l)$ deposits only produce $(D_t^l / (1 + r_t^l))^\lambda$ assets. As long as $\lambda \neq 1$, this would allow equation (A9) to determine D_t^l at the steady state.

¹⁴Since $M_t = 0$ in the long run, \bar{i} must be equal to the equilibrium value of the interbank rate, *i.e.* $\bar{i} = i$.

¹⁵In our model, because of the long run equilibrium in the interbank market, there is no distinction between central bank money and private bank money. In other words, interest and default rates apply to both types of funds. Alternatively, we could assume long run disequilibrium in the interbank market (for instance demand from borrowing firms structurally higher than supply from lending firms). In this case the central bank should permanently supply money $M_t > 0$ and we could distinguish between private bank funds and central bank funds. This alternative route would not change our main results.

$$\bar{\omega}_t = \bar{\omega} \left(\frac{\alpha}{\alpha_{t+1}} \right)^\eta, \quad (15)$$

with $\eta > 0$.¹⁶

2.7 Shock

We introduce a total factor productivity shock following a AR(1) process:

$$\epsilon_t = (\epsilon_{t-1})^{\rho_\epsilon} \exp(u_t^\epsilon). \quad (16)$$

3 Data and calibration

We calibrate the model on average historical real quarterly Luxembourg data (from 1995Q1 to 2007Q3). Luxembourg is an important financial (banking) center and banking data are easily available. We first discuss some features about the banking sector and then explain how we calibrate the model.

3.1 Some facts on the banking sector

Figure 2 shows the aggregate balance sheet of Luxembourg banks (see Appendix B for definitions of the different components and computation details). We see that (i) the interbank market is by far the most important and represents about 50% of assets and liabilities¹⁷, (ii) the size of the market book is also important (23% of assets), (iii) the level of deposits from households is broadly equal to the level of loans to private agents, (iv) own funds represent only 4% of liabilities and (v) net profit is even lower.

Luxembourg is an open economy and data presented in Figure 2 includes deposits and loans from and to residents but also from and to non-residents. Since we have a closed economy model (as does all the literature mentioned in section 1), we would like to discriminate between residents and non-residents. Figure 3 plots the series “loans to resident firms” and “deposits from resident households” (see Appendix B for details). For all the other series, we cannot make the distinction. As in the aggregate data (including both residents *and* non-residents, see Figure 2), deposits are broadly equal to loans. We assume that this result holds in all the other series, *i.e.* that Figure 2 is still accurate if we remove all non-resident input.

¹⁶Similarly, it is obvious that we could introduce Basel II regulations on interbank loans with $\bar{\omega}_t = \bar{\omega}(\delta/\delta_{t+1})^\eta$.

¹⁷Interbank borrowing is not exactly equal to interbank deposits (as it should be in a closed economy) because Luxembourg banks have borrowing/lending relationships with banks abroad (and especially within the Euro Area).

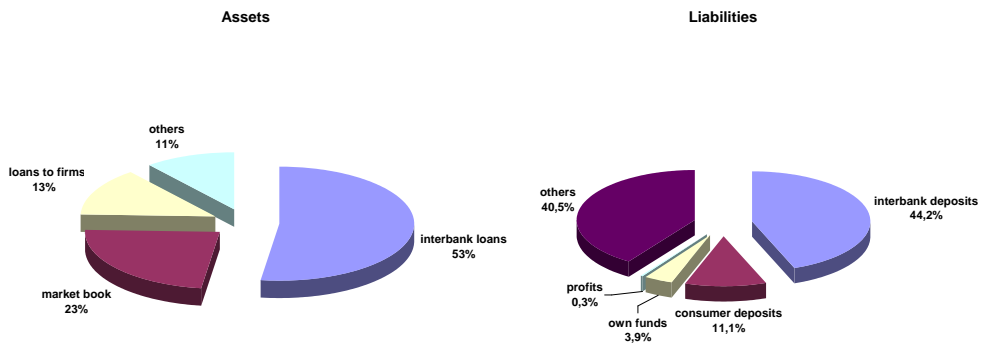

Figure 2: Aggregate balance sheet of Luxembourg banks (average 1995Q1-2007Q3)

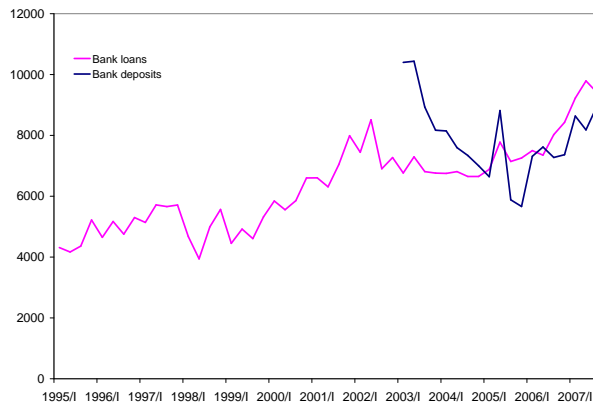

Figure 3: Deposits and loans from and to residents

Figure 4 displays the evolution of yearly real interest rates on the lending market, the interbank market and the borrowing market (see Appendix B for definitions and deflation methodology). We see that the fluctuations are very similar and that the lending rate is on average 3% lower than the borrowing rate. The interbank rate always stands between the lending and the borrowing rates. We also notice the very recent increase in the interbank rate due to the subprime turbulences.

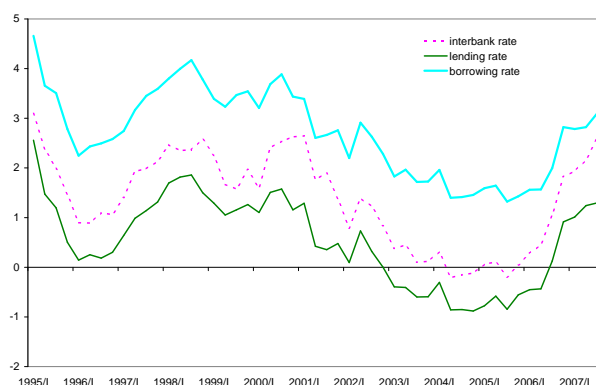

Figure 4: Evolution of yearly real interest rates

Finally we compute, using the Z-score method, a default probability for banks (probability that the debt is higher than the own funds, see Appendix C for details). We see in Figure 5 that this probability is quite low (0.5%) and seems to lag the real interbank interest rate.

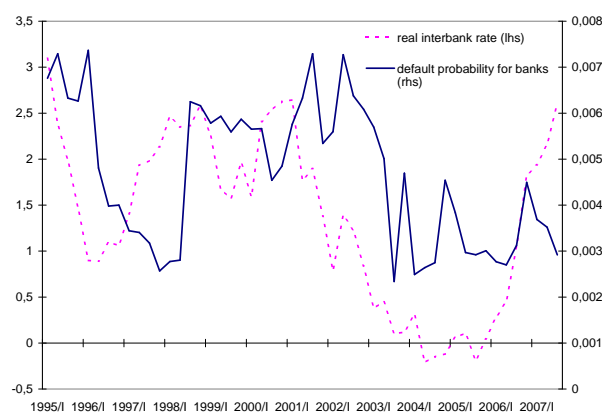

Figure 5: Interbank rate and default probability

3.2 Calibration

We use the facts just described to define our quarterly calibration. From Figures 4 and 5, we derive the average values for the quarterly real interest rates and the bank default probability: $r^b = 1.10\%$ (borrowing rate), $i = 0.34\%$ (interbank rate), $r^l = 0.14\%$ (lending rate) and $1 - \delta = 0.50\%$ (bank default probability). We assume that the market book is mainly invested in European shares. The average real yearly return of the Dow Jones EURO Stoxx from 1995Q1 to 2007Q3 is about 9.5% so we fix our quarterly return $\bar{\rho} = 2\%$. From Figures 2 and 3, we impose that $L^b = D^l$ (deposits=loans) and that $D^{bs} = D^{bd} = 3 \times L^b$ (large size of the interbank market relative to customer loans and deposits). In Figure 2, the market book is about twice as large as the loan volume. However, in our model, this is not sufficient to generate a positive profit for the borrowing bank. To obtain a sufficiently high profit, we need to have a market book three times larger than loans, that is $\bar{B}^b = 3 \times L^b$. We assume that own funds of the borrowing bank covers one fifth of the market book ($F^b = 0.2 \times \bar{B}^b$), exactly as in the data (Figure 2) and, again to insure a sufficiently high profit, we require that the market book is twice higher for lending banks ($2\bar{B}^b = \bar{B}^l$). Finally, according to the Basel accords, minimum own funds cannot be lower than 8% of risk-adjusted assets ($k = 0.08$). This minimum ratio is much lower than what is observed in Luxembourg, suggesting that banks keep a large buffer above the minimum ratio to avoid any risk of penalty. This is consistent with our modelisation, see footnote 11.

From all this, we obtain the discount factor $\beta = 0.999$, deposits $\bar{D}^l = 0.207$, the default parameter $d_\delta = 0.08$ in the borrowing bank utility function and the penalty cost parameter $\omega^b = 168.50$. This last parameter implies that the total penalty cost for the borrowing bank represents 0.7% of her own funds. Although it is difficult to find real data to compare, our figure does not seem too unrealistic. The Basel weight for loans to private firms is $\bar{\omega} = 0.70$ and the Basel weight for interbank loans is $\bar{\omega} = 0.20$. It implies that buffer utility for merchant and deposit banks are respectively $d_{fb} = 0.06$ and $d_{fl} = 0.04$, and that the Basel weight for market book is $\bar{\omega} = 1.10$. All these weighting values are consistent with the official Basel regulations. The interbank market in OECD countries is almost risk-free and $\bar{\omega}$ must be low. $\bar{\omega}$ is consistent with the fact that loans to firms are about 4 times riskier than loans to banks (see below). The weight of the market book must lie between 0.2 (AAA investments) and 1.5 (riskiest investments). Since we have our market book is only composed of European shares, $\bar{\omega} = 1.10$ seems reasonable. Finally, we assume that 1% of own funds is put every quarter into the insurance fund ($\zeta_b = \zeta_l = 0.01$), which implies that 10% of profits are devoted to own funds ($v_b = v_l = 0.10$), and that 50% of defaulted amounts are reimbursed because of this insurance fund ($\zeta_b = \zeta_l = 0.50$).

The consumption utility function \mathcal{U} is logarithmic. Employment (or total hours) \bar{N} is normalized to 0.2 as in standard RBC models, which gives $\bar{m} = 3.641$.¹⁸ Again, as usual in RBC

¹⁸On average, we work about 20% of total available hours: $0.2 \cong (40 \times 42) / (52 \times 7 \times 24)$.

models, the production function $\mathcal{F}(K_t, N_t) = K_t^\mu N_t^{1-\mu}$ is Cobb-Douglas with labour share = $2/3$, that is $1 - \mu = 2/3$, and $K/\mathcal{F} = 10$. We fix the firm's repayment rate at 98%, meaning that the default probability of the firm is around 4 times higher than the default probability of the bank. Although we do not have specific data for firm default, we believe that this seems realistic. Finally, we set the capital depreciation rate $\tau = 3.2\%$. Related studies usually assume a capital depreciation of 2.5%. However, in our model, such a value would imply a negative search cost. Increasing the depreciation rate gives $\gamma = 142.90$, which entails total default costs for firms of 0.2% of output. Our calibration also implies that the weight parameter $d_f = 0.08$ in the firm utility function and that firm profits represent 1.2% of output.

The remaining parameters to calibrate are dynamic and hence do not affect the steady state. θ governs the capital demand function and is used to obtain a realistic r_t^b reaction ($\theta = 5$). The smoothing parameter for deposits is set close to 0 ($\chi = 0.01$) to avoid any dynamic effects (see footnote 13). The monetary policy rule is $\nu = 0$ (no central bank intervention) or $\nu = 10$ (central bank intervention to stabilise the interbank rate around $\bar{i} = 0.34\%$). Fixing $\eta = 0$ implies that the credit weight is fixed (Basel I) whereas $\eta > 0$ implies that the weight is risk-sensitive (Basel II). Finally, the autocorrelation parameter for the productivity shock is $\rho_\epsilon = 0.95$ (RBC literature) and $u_t^\epsilon \sim (0, \sigma_\epsilon^2)$ with $\sigma_\epsilon = 0.01$.

The summary of the calibration as well as the implied values for variables are given in Tables 1 and 2.

Firms			
$d_f = 0.08$	$\gamma = 142.90$	$\mu = 0.333$	$\tau = 0.032$
Banks			
$k = 0.08$	$\bar{\omega} = 0.7$	$\bar{\omega} = 0.2$	$\bar{\omega} = 1.10$
$d_\delta = 23.33$	$\omega^b = 168.50$	$B^b = 0.62$	$B^l = 1.24$
$d_{F^b} = 0.063$	$\zeta_b = 0.50$	$\zeta_b = 0.01$	$v_b = 0.10$
$d_{F^l} = 0.036$	$\zeta_l = 0.50$	$\zeta_l = 0.01$	$v_l = 0.10$
$\bar{\rho} = 0.02$			
Households			
$\beta = 0.999$	$\bar{m} = 3.641$	$D^l = 0.207$	
Dynamics			
$\theta = 5$	$\chi = 0.01$	$\bar{i} = 0.0034$	$\nu = 0/10$
$\eta = 0/10$	$\rho_\epsilon = 0.95$	$\sigma_\epsilon = 0.01$	

Table 1: Calibrated parameter values

Interest and repayment rates				
$r^l = 0.10\%$	$i = 0.34\%$	$r^b = 1.10\%$	$\delta = 0.995$	$\alpha = 0.98$
Assets and liabilities				
$\frac{D^l}{L^b} = 1$	$\frac{D^b}{L^b} = 3$	$\frac{B^b}{L^b} = 3$	$\frac{F^b}{B^b} = 0.2$	$\frac{B^l}{B^b} = 2$
Production, penalty costs and profits				
$\frac{K}{F} = 10$	$\frac{\pi^f}{F} = 1.1\%$	$\frac{tpcf}{F} = 0.2\%$	$\frac{tpcb}{F^b} = 0.7\%$	$\bar{N} = 0.20$

$tpcf = \text{total penalty costs for firms} = \frac{\gamma}{2} ((1 - \alpha)L^b)^2$, $tpcb = \text{total penalty costs for banks} = \frac{\omega^b}{2} ((1 - \delta)D^{bd})^2$.

Table 2: Implied values for variables

4 Simulations

In this section, we first describe the role of the endogenous default rates, the consequence of introducing risk-sensitive capital requirements for the banks as in the Basel II regime, and the effects of liquidity interventions by the central bank. Then, in the RBC tradition, we check if the model is able to reproduce some important stylized facts. We finally look at optimal monetary policy (liquidity injections) under Basel I *vs.* Basel II regimes for a central bank following two objectives: GDP stability and financial stability.

4.1 On the role of endogenous repayment rates

The repayment rate α appears on both sides of the loans market for firms. Assuming a Cobb-Douglas production function (see section 3.2), and posing $\beta = 1$ and $d_f = 0$, the demand side of the credit market represented by first order conditions (A2), (A3) and (A4), see Appendix A, simplifies in the steady state to:

$$\left(L^b\right)^{1-\mu} = \frac{c}{(1+r^b)}, \quad (17)$$

$$(1-\alpha) = \frac{1}{\gamma L^b}, \quad (18)$$

where $c = \mu \frac{N^{1-\mu}}{\tau^\mu}$ is a constant. Equation (17) is the negatively sloped credit demand and equation (18) indicates that the quadratic penalty costs yield the default rate $(1 - \alpha)$ to be decreasing with the demand for loans. On the supply side, first order condition (A7) simplifies to (assuming no insurance fund):

$$\frac{1}{1+r^b} = \alpha - \frac{d_{F^b} k \bar{\omega}}{\lambda^b}, \quad (19)$$

meaning that the interest rate r^b depends negatively on the repayment rate α . The reason is that banks are *in fine* not interested in the gross return on loans $r^b/(1+r^b)$ but on the net return which depends positively on the firm repayment rate. Interest rate and repayment rate are (imperfect) substitute in the borrowing banks net return. From this we can infer that an increase in the demand for loans following a positive shock will (i) decrease the firms default rate, i.e. the risk incurred by the merchant bank, (ii) which yields a relatively lower price of loans for firms and (iii) increases further their loans demand. This typically reproduces the mechanism of a financial accelerator. Would we impose α to be fixed, the substitution effect in the composition of the borrowing banks net return would disappear, and the financial accelerator would collapse.

The same mechanism can be described on the interbank market. On the demand side, first order conditions (A6) and (A5) simplifies in the steady state to:

$$\frac{1}{1+i} = \delta + \omega^b(1-\delta)^2 D^{bd}, \quad (20)$$

$$(1-\delta) = \frac{D^{bd} - d_\delta/\lambda^l}{\omega^b(D^{bd})^2}. \quad (21)$$

Equation (20) is the negatively sloped demand for loans on the interbank market and equation (21) displays that the quadratic penalty cost yields a negative correlation between the demand for loans D^{bd} and the borrowing bank default rate $(1-\delta)$, as long as d_δ is sufficiently small.¹⁹ On the supply side, the first order condition (A10) becomes:

$$\frac{1}{1+i} = \delta(1-\zeta^l) - \frac{d_{Fl}k\bar{\omega}}{\lambda^l} + \zeta^l, \quad (22)$$

showing the negative relationship between the borrowing banks repayment rate and the interest rate obtained by the deposit banks on the interbank market explained by their (imperfect) substitubility in the composition of the deposit banks net return. In case of a positive shock, the increased demand for loans on the interbank market will lead to an increase in the repayment rate δ , yielding a relative decrease in the interbank interest rate and a higher demand for loans from the banks borrowing on the interbank market. This is the second accelerator of the model. From this twin mechanism, we see that the above described model allows for a potential contagion and amplification of banking sector shock to the real activity and *vice versa*.

As an illustration, we can conduct two alternative simulations for a positive productivity shock (TFP shock for the firm). At this stage, let us consider an economy with no central bank (no liquidity injections) and a Basel I regime (benchmark economy). In the first simulation the firm and bank repayment rates are exogenous and in the second, the firm and bank repayment rates are endogenous. Figure 6 shows the difference between the second and the first simulations,

¹⁹More precisely, we must have $(2d_\delta/\lambda^l - D^{bd}) < 0$.

that is shows the size of the financial accelerator. The positive shock increases firm and bank repayment rates which in turn decrease r_t^b (and hence what we call risk premium in Figure 6, that is the spread $r_t^b - r_t^l$) and i_t (and hence the spread $i_t - r_t^l$). The falls in the risk premia act as a double accelerator amplifying the productivity shock and stimulating further employment and output.²⁰ It is worth noting that the - positive - variation in bank repayment rate is very weak compared to the - positive - variation in firm repayment rate, meaning that bank default rate (the second financial accelerator) does not much affect the business cycle. As a result, as in Goodhart et al. (2005), we do not find serious contagion through the interbank default, at least for a productivity shock. Also note that similar financial accelerators would happen with liquidity injections and/or a Basel II regime.

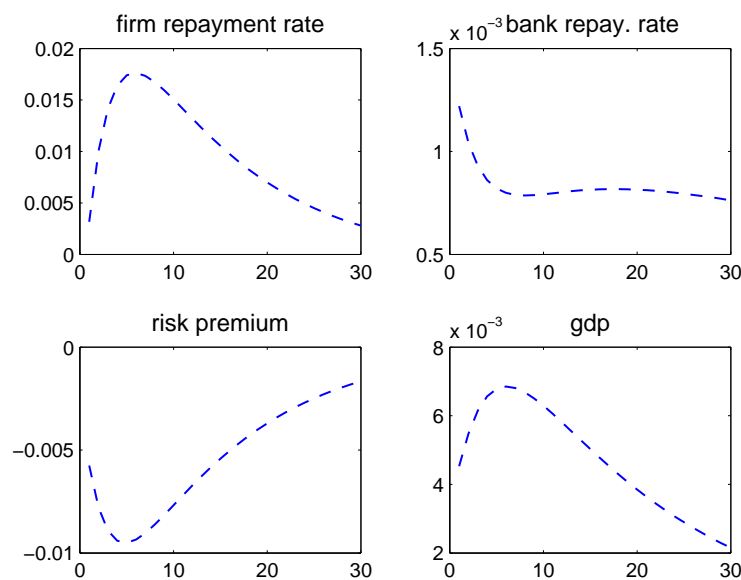

Figure 6: Endogenous repayment rates and size of the financial accelerator

4.2 About risk-sensitive own funds requirement

Let us first assess the effects of the Basel requirements for the merchant banks from a steady state analysis. After an increase in α (positive or procyclical shock), the capital adequacy requirement for the merchant banks remains unchanged under Basel I whereas capital requirement decreases under Basel II. In other words, a higher α implies $\bar{\omega}_{II} < \bar{\omega}_I$. From the loan

²⁰This confirms alternative approaches showing the importance of credit market imperfections to accelerate shocks. See for instance Bernanke et al. (1999) with asymmetry of information and agency costs or Wasmer and Weil (2004) with sequential search and matching processes.

supply first order condition (19), we obtain:

$$\frac{1}{1+r_I^b} - \frac{1}{1+r_{II}^b} = \frac{d_{Fbk}}{\lambda^b} (\bar{\omega}_{II} - \bar{\omega}_I). \quad (23)$$

It is straightforward that $\bar{\omega}_{II} < \bar{\omega}_I \Rightarrow r_{II}^b < r_I^b$, meaning that after a positive shock on α , the borrowing rate will be lower under a Basel II regulation than under a Basel I regulation. From the loan demand first order condition (19), it also means that L^b and hence GDP and employment will be further stimulated with a Basel II regulation.²¹

Would this partial equilibrium result on the procyclicality of Basel II be confirmed in our general equilibrium setup? To answer the question, we introduce the transitory productivity shock (16) and let $\bar{\omega}_t$ vary negatively with firms expected repayment rate α_{t+1} as displayed on equation (15) (for $\eta > 0$). Figure 7 shows the difference between impulse response functions to the shock under Basel II *vs.* Basel I regulations. We see that, under Basel II, the effect of α_{t+1} on $\bar{\omega}_t$ acts as an extra positive shock on loans supply, reducing further the borrowing rate r_t^b and accordingly, the interest rate spread $r_t^b - r_t^l$. From the firm's first order condition (A3), this enhances the demand for loans which further stimulates GDP and employment. In our dynamic general equilibrium model, the procyclical effect of Basel II type of regulations is confirmed: it yields a multiplier effect amplifying the effects of the transitory productivity shock.

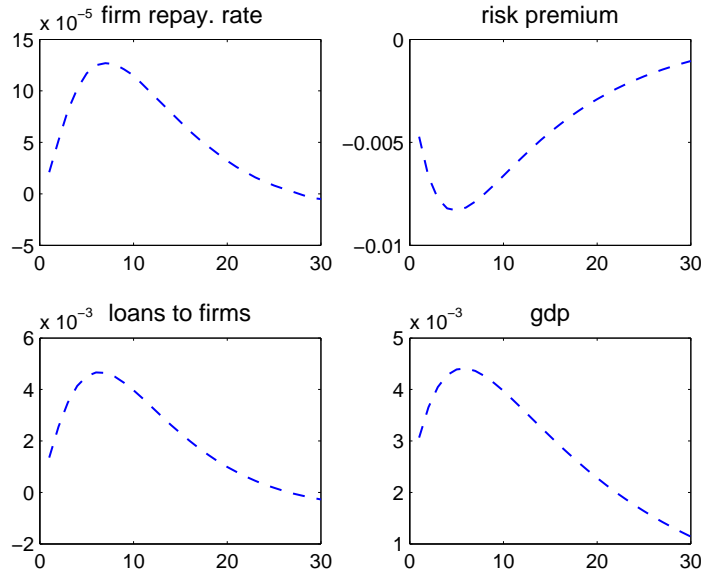

Figure 7: Procyclical effects of Basel II

²¹A Basel II regulation on interbank loans (see footnote 16) would of course produce the same procyclical effects through interactions between equations (20) and (22).

4.3 Liquidity injections

We now describe how liquidity injections affect our economy. In order to catch some intuition, let us first consider an unexpected liquidity injection by the central bank. The sudden rise in M leads to an extra supply of loans on the interbank market and results in a drop in the interbank rate, leading to a larger repayment rate δ and more demand for loans D^{bd} (see subsection 4.1). This increases the merchant bank's profit, see equation (7), and decreases its associated shadow price λ^b (see equation (A8) in Appendix A). *Ceteris paribus*, this yields a drop in the firms borrowing rate r^b through the first order condition (A7) representing the supply of loans by the merchant bank. The drop in r^b increases the firms expected repayment rate as well as the firms' demand for loans, see equations (A2) and (A3). This mechanism matches the intuition that liquidity injections are enhancing the economic activity or, put it differently, that liquidity injections relieve the negative impact of an adverse shock.

The symmetric mechanism can be described on the upstream side of the interbank relationship. The drop in i affects negatively the deposit bank's profit, even though this can be attenuated by the increase in the merchant bank repayment rate δ . It transmits via its associated shadow price λ^l , see equation (A11), of the deposit bank to a decrease in the interest rate on households deposits. This has a decreasing effect on the households supply of deposits.

Having this process in mind, it is easier to understand how letting $\nu > 0$ in the McCallum rule (14) will modify the reaction of the economy after a - positive - productivity shock. This is illustrated on Figure 8 which displays the impulse response function for some variables with $\nu = 0$ and $\nu = 10$.²² Because of the quadratic investment adjustment costs at the firm level, interest rates react negatively to the shock. This means that the central bank which applies rule (14) will withdraw liquidity in order to stabilise the interbank interest rate. This triggers the mechanism described earlier in this subsection, but in the opposite direction. On impact the central bank favours the deposit bank, buying the excess of loans supply D_t^{bs} and preventing the interbank rate to drop. On the other side, the lower drop in interest rates is detrimental to merchant banks which lowers their loan supply to firms L_t^b , inducing a relative drop in the firms repayment rate α_t . *On the short term*, the impacts of the productivity shock are therefore reduced by liquidity interventions.

Beside this impact effect, the central bank intervention has a delayed effect. Money withdrawals sustain artificially the loans supply on the interbank market, and this makes the disequilibrium more persistent. A more persistent disequilibrium means interest rates that remain below equilibrium for longer, with the consequence that after some periods, the initial economy stabilizing effect of the injection will turn into a procyclical one. This is clearly illustrated on Figure 8: the repayment rate α_t is reduced by the central bank intervention in the short run. But from the

²² $\nu = 10$ implies that central bank interventions represent on average 5% of the interbank market volume.

moment money withdrawals bring the interbank interest rate below what it would have been in the absence of intervention, α_t increases with respect to its no-intervention level. As a result, *in the long run*, liquidity interventions increase the persistence of the shock effects on economic activity.

Note however that, whatever in the the short or in the long run, liquidity interventions unambiguously lead to less financial instability, measured as the volatility of the merchant bank repayment rate.

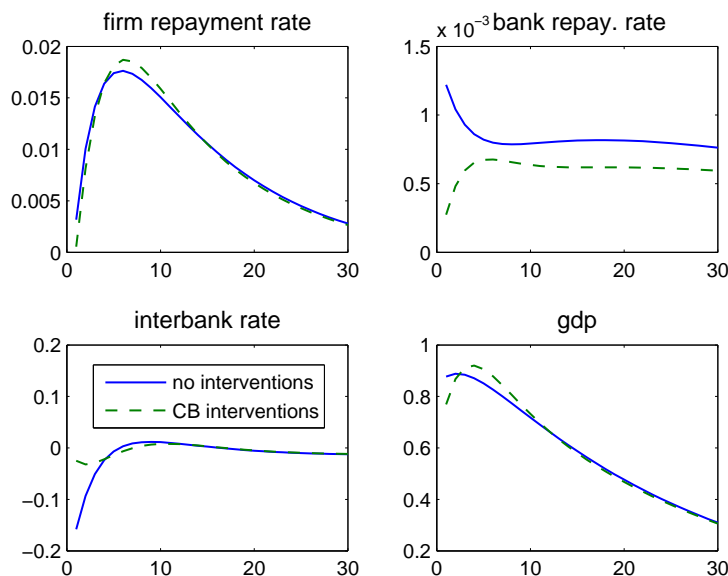

Figure 8: Effects of central bank liquidity interventions

4.4 Stylized facts and simulations results

As usual in the RBC literature, we would like to check if the quantitative implications of our model are realistic. To do so, we compute real data moments for interest rates, repayment rates and production, and we compare these moments to those obtained from our simulated data. Conversely to the standard RBC literature, our model allows to distinguish between three different interest rates (deposit, interbank and borrowing) and to look at firm and bank default rates. Real data moments are displayed in columns “data” of Table 3 and show (i) a weak volatility of the interest and repayment rates (ii) a negative correlation between interest rates and output (similar observations to (i) and (ii) could be found in US or EA data), (iii) procyclical

repayment rates, (iv) countercyclical risk premium and (v) strong persistence of all variables.²³ Simulated moments are reported in columns “model” of Table 3. We assume a Basel I regulation and the liquidity rule is chosen to obtain a realistic volatility of the interbank interest rate, *i.e.* we set $\nu = 10$ in equation (14). As a result, central bank interventions (injections or withdrawals of liquidities) represent on average 5% of the interbank market volume. We show that our model is able to generate realistic volatilities for all variables and to reproduce the negative correlation of all the interest rates and the risk premium with output, the positive correlation of the repayment rates, as well as the strong persistence. The liquidity rule obviously reduces the interbank rate volatility (without liquidity interventions, the volatility would be about 6 times higher) but also reduces other interest rate volatilities and is therefore crucial for these results. The negative correlation of interest rates with output is mainly due to the investment cost: the investment demand cannot immediately jump after a positive productivity shock which induces an initial fall in r_t^b which is spread to the other interest rates. Finally, it is worth noting that, except a large increase in the volatility of the risk premium (see section 4.2 for a discussion), conducting the same simulations under a Basel II regulation would only slightly change the results.

	relative standard deviation		correlation with output		first-order autocorrelation	
	data	model	data	model	data	model
r_t^b	0.05	0.09	-0.58	-0.54	0.90	0.87
i_t	0.05	0.08	-0.43	-0.34	0.91	0.88
r_t^l	0.05	0.08	-0.49	-0.33	0.92	0.88
rp_t	0.01	0.02	-0.42	-0.98	0.76	0.94
α_t	NaN	0.01	NaN	0.87	NaN	0.96
δ_t	0.01	0.01	0.38	0.83	0.75	0.97
N_t	0.74	0.46	0.99	0.93	0.99	0.92
gdp_t	1.00	1.00	1.00	1.00	0.99	0.92

All variables have been logged with the exception of the real interest rates and default rates. Real data: see Appendix B. r_t^b : borrowing rate, i_t : interbank rate, r_t^l : deposit rate, $rp_t = r_t^b - r_t^l$: risk premium, α_t : firm repayment rate, δ_t : bank repayment rate, N_t : employment, $gdp_t = C_t + K_t - (1 - \tau)K_{t-1} + F_t^b + F_t^l - (1 - \xi_b)F_{t-1}^b - (1 - \xi_l)F_{t-1}^l$: gross domestic product.

Table 3: Cyclical properties

²³Real data are from Luxembourg and are only available from 1995Q1 until 2007Q3. Given the limited length of this sample, we do not compute the business cycle deviations from the HP trend but from the mean. To get comparable statistics, we follow the same approach with simulated data (split into sub-samples of 51 observations, see Hendry (1984) for a discussion on the sampling methodology).

4.5 Optimal monetary policy

In our model, the instrument of the central bank policy is liquidity injections M_t and the policy rule is given by equation (14):

$$M_t = \nu (i_t - \bar{i}).$$

In this section, we study the optimal rule to implement in case of disturbances (TFP shock). We first assume that the stabilization goal is to minimise a quadratic loss function of the form:

$$\mathcal{L}_0^{gdp} = \sum_{t=0}^{\infty} \beta^t (g\hat{d}p_t)^2,$$

i.e. the central bank minimises output fluctuations.²⁴ Alternatively, we assume that the central bank is directly interested in financial stability and seeks to minimise bank default fluctuations:

$$\mathcal{L}_0^{\delta} = \sum_{t=0}^{\infty} \beta^t (\hat{\delta}_t)^2.$$

In Figure 9, we plot the values of \mathcal{L}_0^{gdp} and \mathcal{L}_0^{δ} , obtained by simulating a second order approximation of the model, for different values of ν (reaction to interbank rate deviations). We see that a higher interbank rate stability (that is a higher ν) increases financial stability. This result is obvious since the bank default rate $1 - \delta_t$ directly depends on the interbank rate, see equation (A6) and discussion in section 4.3. The effect of a higher interbank rate stability on output stability is ambiguous: depending on the importance of the ν parameter, central bank interventions according to a McCallum rule may either increase or decrease the volatility of the economic activity. Indeed, section 4.3 shows that liquidity injections stabilise the economy in the short run but not in the long run. The total resulting effect depends on the relative importance these two opposite forces. But in any case, the quantitative effect of the liquidity rule on output fluctuations is weak, with a loss function fluctuating only between 8.19 and 8.23, that is a 0.5% difference.²⁵

Finally, moving from a Basel I regime to a Basel II regime helps to reduce further financial instability (the curve moves left) but increases output instability (the curve moves up). This last result is obvious because of the procyclicality of Basel II, see again section 4.2 for a discussion.

²⁴Since we do not have a nominal model, the central bank objective has nothing to do with nominal variables. See for instance Woodford (2003) for an extensive discussion of optimal monetary policies.

²⁵Pushing ν above 100 could strongly reduce further GDP fluctuations (although leaving almost unchanged δ_t fluctuations), but this would imply very large liquidity operations ($\nu = 100$ means that on average, central bank interventions represent 20% of the interbank market volume).

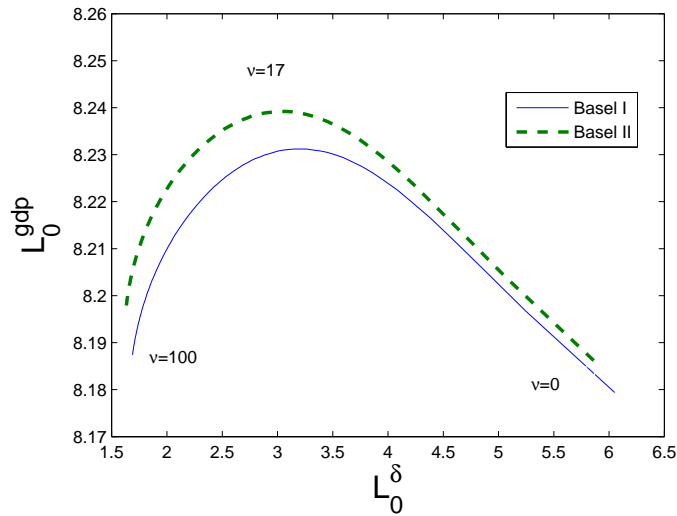

Figure 9: Optimal monetary policy: stabilising output *vs.* default rate

5 Conclusion

Over the past decade, financial stability issues have become an important research field for academics and a very visible objective for policymakers and central banks. A majority of central banks and several international financial institutions, such as the IMF and the BIS, have begun publishing regular reports on this field. However, most of this research and analysis remain descriptive and/or based on partial equilibrium analysis. We think that a consistent framework for financial stability analysis must account for all linkages and diffusion processes, not only between financial and non-financial sectors, but also within the financial sector itself.

In this paper, we propose a dynamic stochastic general equilibrium model (related to the RBC literature) with an heterogeneous banking sector and endogenous default rates as in Goodhart et al. (2005). We show that this credit market representation generates a financial accelerator, that Basel II is procyclical and that our model reproduces stylized facts on interest rates and default rates. We also show that liquidity injections reduce financial instability but have ambiguous effects on the volatility of the rest of the economy.

This model is relatively simple and could be extended along several directions. First, here we only focus on monetary injections, leaving aside the other main central bank policy instrument: the fixation of the repurchase rate. Proper modelisation of central bank behaviour (auctions at a central bank determine repo rate and market-determined interbank rate with possibility of - liquid - central bank interventions) would be interesting although probably not trivial. Second, we have no nominal dimension in our model. An extension to a New-Keynesian framework

(perfectly competitive firms need to be replaced by monopolistic wholesalers setting Calvo prices and selling intermediate goods to perfectly competitive retailers) would make it possible to study the effects of central bank behaviour on inflation (and therefore to include inflation into the loss function). We leave these works for future research.

References

- Bernanke, B., M. Gertler, and S. Gilchrist (1999). The financial accelerator in a quantitative business cycle framework. In J. Taylor and M. Woodford (Eds.), *Handbook of Macroeconomics*, Volume 1C, Chapter 21, pp. 1341–1393. Amsterdam: North-Holland.
- Borio, C. and H. Zhu (2007). Capital regulation, risk-taking and monetary policy: A missing link in the transmission mechanism? BIS.
- Carlstrom, C. and T. Fuerst (1997). Agency cost, net worth, and business fluctuations: A computable general equilibrium analysis. *American Economic Review* 87(5), 893–910.
- Christiano, L., M. Eichenbaum, and C. Evans (2005). Nominal rigidities and the dynamic effects of a shock to monetary policy. *Journal of Political Economy* 113(1-45), 346–353.
- Cooley, T., R. Marimon, and V. Quadrini (2004). Aggregate consequences of limited contract enforceability. *Journal of Political Economy* 112, 817–847.
- Dubey, P., J. Geanakoplos, and M. Shubik (2005). Default and punishment in general equilibrium. *Econometrica* 73(1), 1–37.
- Elul, R. (2008). Collateral, credit history, and the financial decelerator. *Journal of Financial Intermediation* 17, 63–88.
- Goodfriend, M. and B. B. McCallum (2007). Banking and interest rates in monetary policy analysis: A quantitative exploration. *Journal of Monetary Economics* 54, 1480–1507.
- Goodhart, C., P. Sunirand, and D. Tsomocos (2005). A risk assessment model for banks. *Annals of Finance* 1(2), 197–224.
- Goodhart, C., P. Sunirand, and D. Tsomocos (2006). A model to analyse financial fragility. *Economic Theory* 27, 107–142.
- Hendry, D. (1984). Monte carlo experimentation in econometrics. In Z. Griliches and M. Intriligator (Eds.), *Handbook of Econometrics*, Volume II, Chapter 16, pp. 937–976. Amsterdam: North-Holland.
- King, R. and S. Rebelo (1999). Resuscitating real business cycles. In J. Taylor and M. Woodford (Eds.), *Handbook of Macroeconomics*, Volume I B, Chapter 14. Amsterdam: North-Holland.
- Kiyotaki, N. and J. Moore (1997). Credit cycles. *Journal of Political Economy* 105, 211–248.
- Maechler, A., S. Mitra, and D. Worrell (2007). Decomposing financial risks and vulnerabilities in Eastern Europe. IMF Working Paper No. WP/07/248.

- Markovic, B. (2006). Bank capital channels in the monetary transmission mechanism. Bank of England Working Paper no. 313.
- McCallum, B. (1994). A reconsideration of the uncovered interest rate parity relationship. *Journal of Monetary Economics* 33, 105–132.
- Meh, C. and K. Moran (2004). Bank capital, agency costs, and monetary policy. Bank of Canada Working Paper 2004-6.
- Miyake, A. and T. Nakamura (2007). A dynamic analysis of an economy with banking optimization and capital adequacy regulations. *Journal of Economics and Business* 59(1), 14–27.
- Modigliani, F. and M. Miller (1958). The cost of capital, corporation finance and the theory of investment. *American Economic Review* 48(3), 261–297.
- Smets, F. and R. Wouters (2003). An estimated dynamic stochastic general equilibrium model of the euro area. *Journal of the European Economic Association* 1(5), 1123–1175.
- VanHoose, D. (2008). Bank capital regulation, economic stability, and monetary policy: What does the academic literature tell us? *Atlantic Economic Journal* 36, 1–14.
- Wasmer, E. and P. Weil (2004). The macroeconomics of labor and credit market imperfections. *American Economic Review* 94(4), 944–963.
- Woodford, M. (2003). *Interest and Prices*. Princeton University Press.

A First order conditions

A.1 Firms

The optimisation yields the following first order conditions, with λ_t defined as the shadow value of capital:

$$\epsilon_t \mathcal{F}_{N_t} = w_t, \quad (\text{A1})$$

$$\epsilon_t \mathcal{F}_{K_t} = \lambda_t - \tilde{\beta}_{t+1}(1 - \tau)\lambda_{t+1}, \quad (\text{A2})$$

$$\frac{\lambda_t}{1 + r_t^b} - \theta \left(\frac{L_t^b}{1 + r_t^b} - \frac{L_{t-1}^b}{1 + r_{t-1}^b} \right) = \tilde{\beta}_{t+1} \left(\alpha_{t+1} - \theta \left(\frac{L_{t+1}^b}{1 + r_{t+1}^b} - \frac{L_t^b}{1 + r_t^b} \right) \right) + \tilde{\beta}_{t+2} \gamma (1 - \alpha_{t+1})^2 L_t^b, \quad (\text{A3})$$

$$L_{t-1}^b = \tilde{\beta}_{t+1} \gamma (1 - \alpha_t) \left(L_{t-1}^b \right)^2 + d_f. \quad (\text{A4})$$

Equation (A1) equalises the marginal productivity of labour and wages. Equation (A2) defines the marginal productivity of capital as its shadow value today minus its discounted shadow value tomorrow, and equation (A3) says that the shadow value of capital today is equal to its discounted expected cost (a fraction α_t will be paid back tomorrow and a penalty cost on the remaining fraction will be paid two periods ahead). Equation (A4) equalises the marginal cost of paying back today to the discounted marginal search cost of tomorrow plus the marginal disutility term.

A.2 Merchant banks

The maximization program yields:

$$\lambda_t^b D_{t-1}^{bd} = \tilde{\beta}_{t+1} \lambda_{t+1}^b \omega^b (1 - \delta_t) \left(D_{t-1}^{bd} \right)^2 + d_\delta, \quad (\text{A5})$$

$$\frac{\lambda_t^b}{1 + i_t} = \tilde{\beta}_{t+1} \lambda_{t+1}^b \delta_{t+1} + \tilde{\beta}_{t+2} \lambda_{t+2}^b \omega^b (1 - \delta_{t+1})^2 D_t^{bd}, \quad (\text{A6})$$

$$\frac{\lambda_t^b}{1 + r_t^b} = \tilde{\beta}_{t+1} \lambda_{t+1}^b \alpha_{t+1} + \zeta_b \tilde{\beta}_{t+2} \lambda_{t+2}^b (1 - \alpha_{t+1}) - d_{F^b k} \bar{w}_t, \quad (\text{A7})$$

$$d_{F^b v_b} = \left(\lambda_t^b - \frac{1}{\pi_t^b} \right) - \tilde{\beta}_{t+1} (1 - \zeta_b) \left(\lambda_{t+1}^b - \frac{1}{\pi_{t+1}^b} \right). \quad (\text{A8})$$

The Lagrange multiplier associated with the constraint (7) is represented by λ_t^b . Equation (A5) is the trade off between paying back today and paying a penalty tomorrow. Equations (A6) and (A7) are Euler equations respectively for borrowing (from the interbank market) and lending (to firms).

A.3 Deposit banks

The maximization program yields:

$$\frac{\lambda_t^l}{1+r_t^l} = \tilde{\beta}_{t+1} \lambda_{t+1}^l, \quad (\text{A9})$$

$$\frac{\lambda_t^l}{(1+i_t)} = \tilde{\beta}_{t+1} \lambda_{t+1}^l \delta_{t+1} + \zeta_l \tilde{\beta}_{t+2} \lambda_{t+2}^l (1-\delta_{t+1}) - d_{Fl} k \bar{w}, \quad (\text{A10})$$

$$d_{Fl} v_l = \left(\lambda_t^l - \frac{1}{\pi_t^l} \right) - \tilde{\beta}_{t+1} (1-\zeta_l) \left(\lambda_{t+1}^l - \frac{1}{\pi_{t+1}^l} \right). \quad (\text{A11})$$

The Lagrange multiplier associated with the constraint (10) is represented by λ_t^l . Equations (A9) and (A10) are Euler equations for respectively deposits (from households) and loans (to the interbank market).

A.4 Households

The maximization program yields:

$$\frac{\mathcal{U}_{C_t}}{1+r_t^l} = \beta \mathcal{U}_{C_{t+1}} - \chi \left(\frac{D_t^l}{1+r_t^l} - \frac{\bar{D}^l}{1+r^l} \right), \quad (\text{A12})$$

$$\frac{\bar{m}C_t}{1-N_t} = w_t. \quad (\text{A13})$$

Equation (A12) is the Euler equation for consumption augmented with the deposit target term and equation (A13) is the labour supply first order condition.

B Data sources

Real quarterly Luxembourg data from 1995Q1 to 2007Q3. Daily and monthly data are transformed to quarterly ones. Nominal data are deflated by the Eurozone HICP (monthly data transformed to quarterly ones). We use the Eurozone HICP (instead of the Luxembourg one) because this is the reference inflation for the conduct of the monetary policy and hence the interest rate evolutions. Data presented in Figure 2 and used for the calibration are average over the sample period. More precisely:

- Interbank loans: include all loans and advances to credit institutions, repayable on demand or with agreed maturity. Data aggregated from individual bank balance sheets. Source: Central Bank of Luxembourg.
- Market book: includes debt securities, other fixed-income securities, shares and other variable-yield securities. Data aggregated from individual bank balance sheets. Source: Central Bank of Luxembourg.

- Loans to private agents (non financial companies): data aggregated from individual bank balance sheets. Distinction is made between total loans (to resident and non resident companies) and loans to only resident companies. Source: Central Bank of Luxembourg.
- Others (assets): defined as the difference between total assets and the sum of market book, interbank loans and loans to private companies.
- Interbank deposits: data aggregated from individual bank balance sheets. Source: Central Bank of Luxembourg.
- Consumer deposits: include all consumer deposits, *i.e.* term and sight deposits. Data aggregated from individual bank balance sheets. Source: Central Bank of Luxembourg.
- Own funds: subscribed capital plus reserves including the past profits bring forward. Data aggregated from individual bank balance sheets. Source: Central Bank of Luxembourg.
- Profits: data aggregated from quarterly loss and profit account. Source: Central Bank of Luxembourg.
- Others (liabilities): defined as the difference between total liabilities and the sum of interbank and consumer deposits, own capital and the profit.
- Lending rate: quarterly average rate of lending to non financial companies. Source: Central Bank of Luxembourg.
- Interbank rate: until 1995, Belgian 3-month interbank rate (Eurostat), from 1996, Euribor 3-month (Bloomberg).
- Borrowing rate: quarterly average rate on consumer deposits. Source: Central Bank of Luxembourg.
- Default rate for banks: see Appendix C.
- Capital ratio: related to the Basel II accord which defines the ratio as the sum of the two components of the bank capital, *i.e.* Tier I and Tier II, divided by risk adjusted assets. The latter are defined by affecting each balance sheet and off-balance sheet asset into a risk category (the riskier the assets, the larger the weight). The weight varies from zero to 150 percent. Source: Luxembourg supervisory authority (CSSF).

C Z-score: an application to Luxembourg bank default

The z-score index is a distance to default indicator (DD) calculated from bank's balance sheet and profit account (rather than an option-based measure as the standard DD indicator). The

advantage of the z-score (book value) relative to DD (market value) is the possibility to evaluate the default risk of non listed companies.

The z-score is defined as $z = (\mu + k) / \sigma$, where μ is the average return on assets (ROA), k is the ratio of own funds to total assets, and σ is the standard deviation of return on assets (ROA). In other words, the z-score measures the number of standard deviations a return realization would have to fall in order to deplete banks' own funds, under the assumption of normality of returns. As with DD, the higher level of the z-score the better is quality of the bank and the lower is the probability of insolvency.

In this paper, we derived the z-score for Luxembourg individual banks from quarterly financial statements. The sample period covers 1994Q1 to 2007Q3. We adopt the Maechler et al. (2007) approach and use a eight-quarter rolling z-index calculated from the 8 quarters moving average of the three above mentioned variables. We then take the logarithm of the result to get z.

As the z-score is, by assumption, normally distributed with a mean zero and a standard deviation equal 1, the probability of default of a bank i at time t is $P_t^i = F(-z_t)$, where F is the cumulative distribution. The aggregate probabilities of default for the whole banking sector is computed as the mean of individual probabilities.

NATIONAL BANK OF BELGIUM - WORKING PAPERS SERIES

1. "Model-based inflation forecasts and monetary policy rules" by M. Dombrecht and R. Wouters, *Research Series*, February 2000.
2. "The use of robust estimators as measures of core inflation" by L. Aucremanne, *Research Series*, February 2000.
3. "Performances économiques des Etats-Unis dans les années nonante" by A. Nyssens, P. Butzen, P. Bisciari, *Document Series*, March 2000.
4. "A model with explicit expectations for Belgium" by P. Jeanfils, *Research Series*, March 2000.
5. "Growth in an open economy: some recent developments" by S. Turnovsky, *Research Series*, May 2000.
6. "Knowledge, technology and economic growth: an OECD perspective" by I. Visco, A. Bassanini, S. Scarpetta, *Research Series*, May 2000.
7. "Fiscal policy and growth in the context of European integration" by P. Masson, *Research Series*, May 2000.
8. "Economic growth and the labour market: Europe's challenge" by C. Wyplosz, *Research Series*, May 2000.
9. "The role of the exchange rate in economic growth: a euro-zone perspective" by R. MacDonald, *Research Series*, May 2000.
10. "Monetary union and economic growth" by J. Vickers, *Research Series*, May 2000.
11. "Politique monétaire et prix des actifs: le cas des Etats-Unis" by Q. Wibaut, *Document Series*, August 2000.
12. "The Belgian industrial confidence indicator: leading indicator of economic activity in the euro area?" by J.-J. Vanhaelen, L. Dresse, J. De Mulder, *Document Series*, November 2000.
13. "Le financement des entreprises par capital-risque" by C. Rigo, *Document Series*, February 2001.
14. "La nouvelle économie" by P. Bisciari, *Document Series*, March 2001.
15. "De kostprijs van bankkredieten" by A. Bruggeman and R. Wouters, *Document Series*, April 2001.
16. "A guided tour of the world of rational expectations models and optimal policies" by Ph. Jeanfils, *Research Series*, May 2001.
17. "Attractive Prices and Euro - Rounding effects on inflation" by L. Aucremanne and D. Cornille, *Documents Series*, November 2001.
18. "The interest rate and credit channels in Belgium: an investigation with micro-level firm data" by P. Butzen, C. Fuss and Ph. Vermeulen, *Research series*, December 2001.
19. "Openness, imperfect exchange rate pass-through and monetary policy" by F. Smets and R. Wouters, *Research series*, March 2002.
20. "Inflation, relative prices and nominal rigidities" by L. Aucremanne, G. Brys, M. Hubert, P. J. Rousseeuw and A. Struyf, *Research series*, April 2002.
21. "Lifting the burden: fundamental tax reform and economic growth" by D. Jorgenson, *Research series*, May 2002.
22. "What do we know about investment under uncertainty?" by L. Trigeorgis, *Research series*, May 2002.
23. "Investment, uncertainty and irreversibility: evidence from Belgian accounting data" by D. Cassimon, P.-J. Engelen, H. Meersman, M. Van Wouwe, *Research series*, May 2002.
24. "The impact of uncertainty on investment plans" by P. Butzen, C. Fuss, Ph. Vermeulen, *Research series*, May 2002.
25. "Investment, protection, ownership, and the cost of capital" by Ch. P. Himmelberg, R. G. Hubbard, I. Love, *Research series*, May 2002.
26. "Finance, uncertainty and investment: assessing the gains and losses of a generalised non-linear structural approach using Belgian panel data", by M. Gérard, F. Verschuere, *Research series*, May 2002.
27. "Capital structure, firm liquidity and growth" by R. Anderson, *Research series*, May 2002.
28. "Structural modelling of investment and financial constraints: where do we stand?" by J.- B. Chatelain, *Research series*, May 2002.
29. "Financing and investment interdependencies in unquoted Belgian companies: the role of venture capital" by S. Manigart, K. Baeyens, I. Verschuere, *Research series*, May 2002.
30. "Development path and capital structure of Belgian biotechnology firms" by V. Bastin, A. Corhay, G. Hübner, P.-A. Michel, *Research series*, May 2002.
31. "Governance as a source of managerial discipline" by J. Franks, *Research series*, May 2002.

32. "Financing constraints, fixed capital and R&D investment decisions of Belgian firms" by M. Cincera, *Research series*, May 2002.
33. "Investment, R&D and liquidity constraints: a corporate governance approach to the Belgian evidence" by P. Van Cayseele, *Research series*, May 2002.
34. "On the Origins of the Franco-German EMU Controversies" by I. Maes, *Research series*, July 2002.
35. "An estimated dynamic stochastic general equilibrium model of the Euro Area", by F. Smets and R. Wouters, *Research series*, October 2002.
36. "The labour market and fiscal impact of labour tax reductions: The case of reduction of employers' social security contributions under a wage norm regime with automatic price indexing of wages", by K. Burggraeve and Ph. Du Caju, *Research series*, March 2003.
37. "Scope of asymmetries in the Euro Area", by S. Ide and Ph. Moës, *Document series*, March 2003.
38. "De autonijverheid in België: Het belang van het toeleveringsnetwerk rond de assemblage van personenauto's", by F. Coppens and G. van Gastel, *Document series*, June 2003.
39. "La consommation privée en Belgique", by B. Eugène, Ph. Jeanfils and B. Robert, *Document series*, June 2003.
40. "The process of European monetary integration: a comparison of the Belgian and Italian approaches", by I. Maes and L. Quaglia, *Research series*, August 2003.
41. "Stock market valuation in the United States", by P. Bisciari, A. Durré and A. Nyssens, *Document series*, November 2003.
42. "Modeling the Term Structure of Interest Rates: Where Do We Stand?", by K. Maes, *Research series*, February 2004.
43. "Interbank Exposures: An Empirical Examination of System Risk in the Belgian Banking System", by H. Degryse and G. Nguyen, *Research series*, March 2004.
44. "How Frequently do Prices change? Evidence Based on the Micro Data Underlying the Belgian CPI", by L. Aucremanne and E. Dhyne, *Research series*, April 2004.
45. "Firms' investment decisions in response to demand and price uncertainty", by C. Fuss and Ph. Vermeulen, *Research series*, April 2004.
46. "SMEs and Bank Lending Relationships: the Impact of Mergers", by H. Degryse, N. Masschelein and J. Mitchell, *Research series*, May 2004.
47. "The Determinants of Pass-Through of Market Conditions to Bank Retail Interest Rates in Belgium", by F. De Graeve, O. De Jonghe and R. Vander Vennet, *Research series*, May 2004.
48. "Sectoral vs. country diversification benefits and downside risk", by M. Emir, *Research series*, May 2004.
49. "How does liquidity react to stress periods in a limit order market?", by H. Beltran, A. Durré and P. Giot, *Research series*, May 2004.
50. "Financial consolidation and liquidity: prudential regulation and/or competition policy?", by P. Van Cayseele, *Research series*, May 2004.
51. "Basel II and Operational Risk: Implications for risk measurement and management in the financial sector", by A. Chapelle, Y. Crama, G. Hübner and J.-P. Peters, *Research series*, May 2004.
52. "The Efficiency and Stability of Banks and Markets", by F. Allen, *Research series*, May 2004.
53. "Does Financial Liberalization Spur Growth?" by G. Bekaert, C.R. Harvey and C. Lundblad, *Research series*, May 2004.
54. "Regulating Financial Conglomerates", by X. Freixas, G. Lóránth, A.D. Morrison and H.S. Shin, *Research series*, May 2004.
55. "Liquidity and Financial Market Stability", by M. O'Hara, *Research series*, May 2004.
56. "Economisch belang van de Vlaamse zeehavens: verslag 2002", by F. Lagneaux, *Document series*, June 2004.
57. "Determinants of Euro Term Structure of Credit Spreads", by A. Van Landschoot, *Research series*, July 2004.
58. "Macroeconomic and Monetary Policy-Making at the European Commission, from the Rome Treaties to the Hague Summit", by I. Maes, *Research series*, July 2004.
59. "Liberalisation of Network Industries: Is Electricity an Exception to the Rule?", by F. Coppens and D. Vivet, *Document series*, September 2004.
60. "Forecasting with a Bayesian DSGE model: an application to the euro area", by F. Smets and R. Wouters, *Research series*, September 2004.
61. "Comparing shocks and frictions in US and Euro Area Business Cycle: a Bayesian DSGE approach", by F. Smets and R. Wouters, *Research series*, October 2004.

62. "Voting on Pensions: A Survey", by G. de Walque, *Research series*, October 2004.
63. "Asymmetric Growth and Inflation Developments in the Acceding Countries: A New Assessment", by S. Ide and P. Moës, *Research series*, October 2004.
64. "Importance économique du Port Autonome de Liège: rapport 2002", by F. Lagneaux, *Document series*, November 2004.
65. "Price-setting behaviour in Belgium: what can be learned from an ad hoc survey", by L. Aucremanne and M. Druant, *Research series*, March 2005.
66. "Time-dependent versus State-dependent Pricing: A Panel Data Approach to the Determinants of Belgian Consumer Price Changes", by L. Aucremanne and E. Dhyne, *Research series*, April 2005.
67. "Indirect effects – A formal definition and degrees of dependency as an alternative to technical coefficients", by F. Coppens, *Research series*, May 2005.
68. "Noname – A new quarterly model for Belgium", by Ph. Jeanfils and K. Burggraeve, *Research series*, May 2005.
69. "Economic importance of the Flemish maritime ports: report 2003", F. Lagneaux, *Document series*, May 2005.
70. "Measuring inflation persistence: a structural time series approach", M. Dossche and G. Everaert, *Research series*, June 2005.
71. "Financial intermediation theory and implications for the sources of value in structured finance markets", J. Mitchell, *Document series*, July 2005.
72. "Liquidity risk in securities settlement", J. Devriese and J. Mitchell, *Research series*, July 2005.
73. "An international analysis of earnings, stock prices and bond yields", A. Durré and P. Giot, *Research series*, September 2005.
74. "Price setting in the euro area: Some stylized facts from Individual Consumer Price Data", E. Dhyne, L. J. Álvarez, H. Le Bihan, G. Veronese, D. Dias, J. Hoffmann, N. Jonker, P. Lünemann, F. Rumler and J. Vilmunen, *Research series*, September 2005.
75. "Importance économique du Port Autonome de Liège: rapport 2003", by F. Lagneaux, *Document series*, October 2005.
76. "The pricing behaviour of firms in the euro area: new survey evidence, by S. Fabiani, M. Druant, I. Hernando, C. Kwapil, B. Landau, C. Loupias, F. Martins, T. Mathä, R. Sabbatini, H. Stahl and A. Stokman, *Research series*, November 2005.
77. "Income uncertainty and aggregate consumption, by L. Pozzi, *Research series*, November 2005.
78. "Crédits aux particuliers - Analyse des données de la Centrale des Crédits aux Particuliers", by H. De Doncker, *Document series*, January 2006.
79. "Is there a difference between solicited and unsolicited bank ratings and, if so, why?" by P. Van Roy, *Research series*, February 2006.
80. "A generalised dynamic factor model for the Belgian economy - Useful business cycle indicators and GDP growth forecasts", by Ch. Van Nieuwenhuyze, *Research series*, February 2006.
81. "Réduction linéaire de cotisations patronales à la sécurité sociale et financement alternatif" by Ph. Jeanfils, L. Van Meensel, Ph. Du Caju, Y. Saks, K. Buysse and K. Van Cauter, *Document series*, March 2006.
82. "The patterns and determinants of price setting in the Belgian industry" by D. Cornille and M. Dossche, *Research series*, May 2006.
83. "A multi-factor model for the valuation and risk management of demand deposits" by H. Dewachter, M. Lyrio and K. Maes, *Research series*, May 2006.
84. "The single European electricity market: A long road to convergence", by F. Coppens and D. Vivet, *Document series*, May 2006.
85. "Firm-specific production factors in a DSGE model with Taylor price setting", by G. de Walque, F. Smets and R. Wouters, *Research series*, June 2006.
86. "Economic importance of the Belgian ports: Flemish maritime ports and Liège port complex - report 2004", by F. Lagneaux, *Document series*, June 2006.
87. "The response of firms' investment and financing to adverse cash flow shocks: the role of bank relationships", by C. Fuss and Ph. Vermeulen, *Research series*, July 2006.
88. "The term structure of interest rates in a DSGE model", by M. Emiris, *Research series*, July 2006.
89. "The production function approach to the Belgian output gap, Estimation of a Multivariate Structural Time Series Model", by Ph. Moës, *Research series*, September 2006.
90. "Industry Wage Differentials, Unobserved Ability, and Rent-Sharing: Evidence from Matched Worker-Firm Data, 1995-2002", by R. Plasman, F. Rycx and I. Tojerow, *Research series*, October 2006.

91. "The dynamics of trade and competition", by N. Chen, J. Imbs and A. Scott, *Research series*, October 2006.
92. "A New Keynesian Model with Unemployment", by O. Blanchard and J. Gali, *Research series*, October 2006.
93. "Price and Wage Setting in an Integrating Europe: Firm Level Evidence", by F. Abraham, J. Konings and S. Vanormelingen, *Research series*, October 2006.
94. "Simulation, estimation and welfare implications of monetary policies in a 3-country NOEM model", by J. Plasmans, T. Michalak and J. Fornero, *Research series*, October 2006.
95. "Inflation persistence and price-setting behaviour in the euro area: a summary of the Inflation Persistence Network evidence", by F. Altissimo, M. Ehrmann and F. Smets, *Research series*, October 2006.
96. "How Wages Change: Micro Evidence from the International Wage Flexibility Project", by W.T. Dickens, L. Goette, E.L. Goshen, S. Holden, J. Messina, M.E. Schweitzer, J. Turunen and M. Ward, *Research series*, October 2006.
97. "Nominal wage rigidities in a new Keynesian model with frictional unemployment", by V. Bodart, G. de Walque, O. Pierrard, H.R. Sneessens and R. Wouters, *Research series*, October 2006.
98. "Dynamics on monetary policy in a fair wage model of the business cycle", by D. De la Croix, G. de Walque and R. Wouters, *Research series*, October 2006.
99. "The kinked demand curve and price rigidity: evidence from scanner data", by M. Dossche, F. Heylen and D. Van den Poel, *Research series*, October 2006.
100. "Lumpy price adjustments: a microeconomic analysis", by E. Dhyne, C. Fuss, H. Peseran and P. Sevestre, *Research series*, October 2006.
101. "Reasons for wage rigidity in Germany", by W. Franz and F. Pfeiffer, *Research series*, October 2006.
102. "Fiscal sustainability indicators and policy design in the face of ageing", by G. Langenus, *Research series*, October 2006.
103. "Macroeconomic fluctuations and firm entry: theory and evidence", by V. Lewis, *Research series*, October 2006.
104. "Exploring the CDS-Bond Basis" by J. De Wit, *Research series*, November 2006.
105. "Sector Concentration in Loan Portfolios and Economic Capital", by K. Düllmann and N. Masschelein, *Research series*, November 2006.
106. "R&D in the Belgian Pharmaceutical Sector", by H. De Doncker, *Document series*, December 2006.
107. "Importance et évolution des investissements directs en Belgique", by Ch. Piette, *Document series*, January 2007.
108. "Investment-Specific Technology Shocks and Labor Market Frictions", by R. De Bock, *Research series*, February 2007.
109. "Shocks and frictions in US Business cycles: a Bayesian DSGE Approach", by F. Smets and R. Wouters, *Research series*, February 2007.
110. "Economic impact of port activity: a disaggregate analysis. The case of Antwerp", by F. Coppens, F. Lagneaux, H. Meersman, N. Sellekaerts, E. Van de Voorde, G. van Gastel, Th. Vanelslander, A. Verhetsel, *Document series*, February 2007.
111. "Price setting in the euro area: some stylised facts from individual producer price data", by Ph. Vermeulen, D. Dias, M. Dossche, E. Gautier, I. Hernando, R. Sabbatini, H. Stahl, *Research series*, March 2007.
112. "Assessing the Gap between Observed and Perceived Inflation in the Euro Area: Is the Credibility of the HICP at Stake?", by L. Aucremanne, M. Collin, Th. Stragier, *Research series*, April 2007.
113. "The spread of Keynesian economics: a comparison of the Belgian and Italian experiences", by I. Maes, *Research series*, April 2007.
114. "Imports and Exports at the Level of the Firm: Evidence from Belgium", by M. Muïls and M. Pisu, *Research series*, May 2007.
115. "Economic importance of the Belgian ports: Flemish maritime ports and Liège port complex - report 2005", by F. Lagneaux, *Document series*, May 2007.
116. "Temporal Distribution of Price Changes: Staggering in the Large and Synchronization in the Small", by E. Dhyne and J. Konieczny, *Research series*, June 2007.
117. "Can excess liquidity signal an asset price boom?", by A. Bruggeman, *Research series*, August 2007.
118. "The performance of credit rating systems in the assessment of collateral used in Eurosystem monetary policy operations", by F. Coppens, F. González and G. Winkler, *Research series*, September 2007.
119. "The determinants of stock and bond return comovements", by L. Baele, G. Bekaert and K. Inghelbrecht, *Research series*, October 2007.

120. "Monitoring pro-cyclicality under the capital requirements directive: preliminary concepts for developing a framework", by N. Masschelein, *Document series*, October 2007.
121. "Dynamic order submission strategies with competition between a dealer market and a crossing network", by H. Degryse, M. Van Achter and G. Wuyts, *Research series*, November 2007.
122. "The gas chain: influence of its specificities on the liberalisation process", by C. Swartenbroekx, *Document series*, November 2007.
123. "Failure prediction models: performance, disagreements, and internal rating systems", by J. Mitchell and P. Van Roy, *Research series*, December 2007.
124. "Downward wage rigidity for different workers and firms: an evaluation for Belgium using the IWF procedure", by Ph. Du Caju, C. Fuss and L. Wintr, *Research series*, December 2007.
125. "Economic importance of Belgian transport logistics", by F. Lagneaux, *Document series*, January 2008.
126. "Some evidence on late bidding in eBay auctions", by L. Wintr, *Research series*, January 2008.
127. "How do firms adjust their wage bill in Belgium? A decomposition along the intensive and extensive margins", by C. Fuss, *Research series*, January 2008.
128. "Exports and productivity – comparable evidence for 14 countries", by The International Study Group on Exports and Productivity, *Research series*, February 2008.
129. "Estimation of monetary policy preferences in a forward-looking model: a Bayesian approach", by P. Ilbas, *Research series*, March 2008.
130. "Job creation, job destruction and firms' international trade involvement", by M. Pisu, *Research series*, March 2008.
131. "Do survey indicators let us see the business cycle? A frequency decomposition", by L. Dresse and Ch. Van Nieuwenhuyze, *Research series*, March 2008.
132. "Searching for additional sources of inflation persistence: the micro-price panel data approach", by R. Raciborski, *Research series*, April 2008.
133. "Short-term forecasting of GDP using large monthly datasets - A pseudo real-time forecast evaluation exercise", by K. Barhouni, S. Benk, R. Cristadoro, A. Den Reijer, A. Jakaitiene, P. Jelonek, A. Rua, G. Rünstler, K. Ruth and Ch. Van Nieuwenhuyze, *Research series*, June 2008.
134. "Economic importance of the Belgian ports: Flemish maritime ports, Liège port complex and the port of Brussels - report 2006" by S. Vennix, *Document series*, June 2008.
135. "Imperfect exchange rate pass-through: the role of distribution services and variable demand elasticity", by Ph. Jeanfils, *Research series*, August 2008.
136. "Multivariate structural time series models with dual cycles: Implications for measurement of output gap and potential growth", by Ph. Moës, *Research series*, August 2008.
137. "Agency problems in structured finance - a case study of European CLOs", by J. Keller, *Document series*, August 2008.
138. "The efficiency frontier as a method for gauging the performance of public expenditure: a Belgian case study", by B. Eugène, *Research series*, September 2008.
139. "Exporters and credit constraints. A firm-level approach", by M. Muûls, *Research series*, September 2008.
140. "Export destinations and learning-by-exporting: Evidence from Belgium", by M. Pisu, *Research series*, September 2008.
141. "Monetary aggregates and liquidity in a neo-Wicksellian framework", by M. Canzoneri, R. Cumby, B. Diba and D. López-Salido, *Research series*, October 2008.
142. "Liquidity, inflation and asset prices in a time-varying framework for the euro area, by Ch. Baumeister, E. Durinck and G. Peersman, *Research series*, October 2008.
143. "The bond premium in a DSGE model with long-run real and nominal risks", by Glenn D. Rudebusch and Eric T. Swanson, *Research series*, October 2008.
144. "Imperfect information, macroeconomic dynamics and the yield curve: an encompassing macro-finance model", by H. Dewachter, *Research series*, October 2008.
145. "Housing market spillovers: evidence from an estimated DSGE model", by M. Iacoviello and S. Neri, *Research series*, October 2008.
146. "Credit frictions and optimal monetary policy", by V. Cúrdia and M. Woodford, *Research series*, October 2008.
147. "Central bank misperceptions and the role of money in interest rate rules", by G. Beck and V. Wieland, *Research series*, October 2008.
148. "Financial (in)stability, supervision and liquidity injections: a dynamic general equilibrium approach", by G. de Walque, O. Pierrard and A. Rouabah, *Research series*, October 2008.